

# PN Racing Mini-Z Precision Gear Differential

## Parts Number MR2055

- Light weight. Minimal rotational inertia for fast acceleration.
- Fast gear ratio changes. No disassembly of differential necessary for spur gear change.
- Adjustable side gear tension for tight or loose differential action.
- Smooth quiet operation. No gear noise and vibration associated with stock differential.

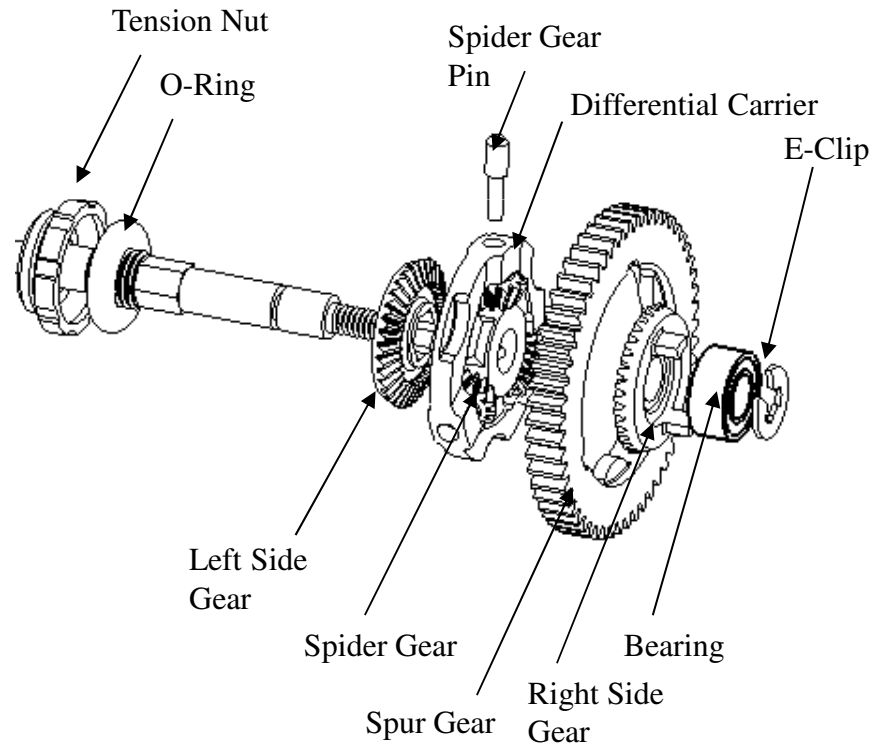

## Changing Spur Gear Ratio

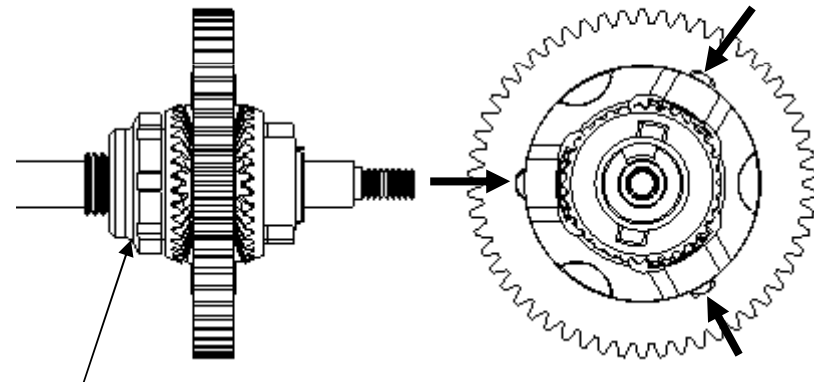

1. Loosen Tension Nut to separate side gears.

2. Allow spider gear pins to recess into carrier. Depress with screw driver if necessary as shown by arrows.

3. Remove spur gear.

4. Installation is reverse of removal